

CKTS	PART NUMBER	PARTS PER BAG	BAGS PER CARTON	PARTS PER CARTON (DU)
8	207017-0008	400	1	400
10	207017-0010	300	1	300

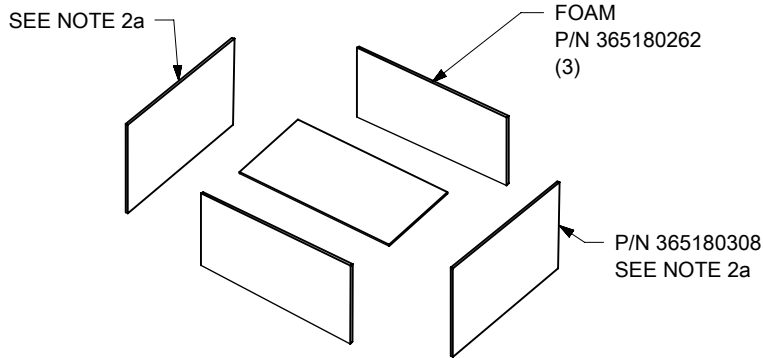

NOTES - PACKAGING PROCEDURE

- FOLD AND TAPE BOTTOM FLAPS OF CARTON WITH 2" WIDE TAPE PER ES-40000-7013. TAPE SHOULD EXTEND UP SIDES OF CARTON AT LEAST 76 MM (3 INCHES). PLACE THE ADHESIVE TAPE IN CENTER & 2 CORNERS
- PLACE THE FOAMS ALL SIX SIDES OF CARTON.
  - CUT THE FOAM P/N 365180308 INTO TWO EQUAL HALVES AND PLACE TWO FACES
- POLYBAGS TO BE FILLED WITH QUANTITY OF PARTS AS SPECIFIED PER CHART AND CLOSE POLYBAG BY HEAT SEALING.
- CLOSE TOP FLAPS OF CARTON AND TAPE. TAPE SHOULD EXTEND DOWN SIDES OF CARTON AT LEAST 76 MM (3 INCHES).
- ADD LABELS TO CARTONS AS REQUIRED PER ES-40000-7012.
- REFER SHEET 2 FOR CKTS 12 & 14. REFER TO SHEET 3 FOR CKTS 4, 6, 16 & 18.

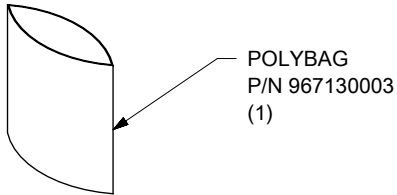
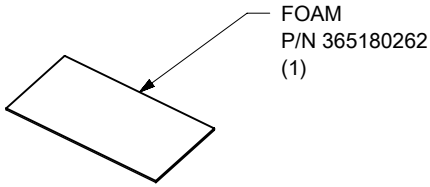
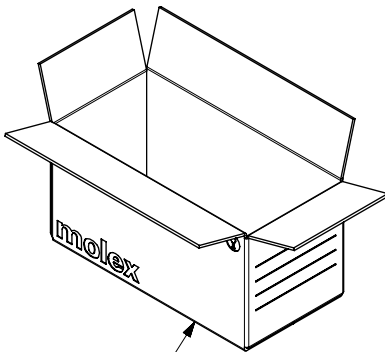

FUNCTIONAL SYMBOLS	THIS DRAWING CONTAINS INFORMATION THAT IS PROPRIETARY TO MOLEX ELECTRONIC TECHNOLOGIES, LLC AND SHOULD NOT BE USED WITHOUT WRITTEN PERMISSION				
	DIMENSION UNITS	SCALE	CURRENT REV DESC:		
$\frac{E}{A} = 0$	mm	NTS	EC NO: 778678 DRWN: GOWTHP 2021/12/30 CHK'D: JERRYW8 2024/02/29 APPR: XQZHANG 2024/03/01		
$\frac{E}{E} = 0$	GENERAL TOLERANCES (UNLESS SPECIFIED)				
$\frac{E}{P} = 0$	ANGULAR TOL ± °				
DIVISIONAL SYMBOLS	4 PLACES	±			
	3 PLACES	±	INITIAL REVISION:		
	2 PLACES	±	DRWN: SSHANMUGAN01 2019/03/12	DOCUMENT NUMBER	DOC TYPE
	1 PLACE	±	APPR: MRAMAKRISHNA 2019/12/19	2070170000-PK	PDD
	0 PLACES	±		000	REVISION
	DRAFT WHERE APPLICABLE MUST REMAIN WITHIN DIMENSIONS		THIRD ANGLE PROJECTION	DRAWING	SERIES
				A-SIZE	207017
				MATERIAL NUMBER	CUSTOMER
				SEE TABLE	GENERAL MARKET
					SHEET NUMBER
					1 OF 3

DOCUMENT STATUS	P1	RELEASE DATE	2024/03/01	05:51:32
-----------------	----	--------------	------------	----------

FORMAT: master-ib-prod-A  
 REVISION: J  
 DATE: 2020/01/14

CKTS	PART NUMBER	PARTS PER BAG	BAGS PER CARTON	PARTS PER CARTON (DU)
12	207017-0012	125	2	250
14	207017-0014	100	2	200

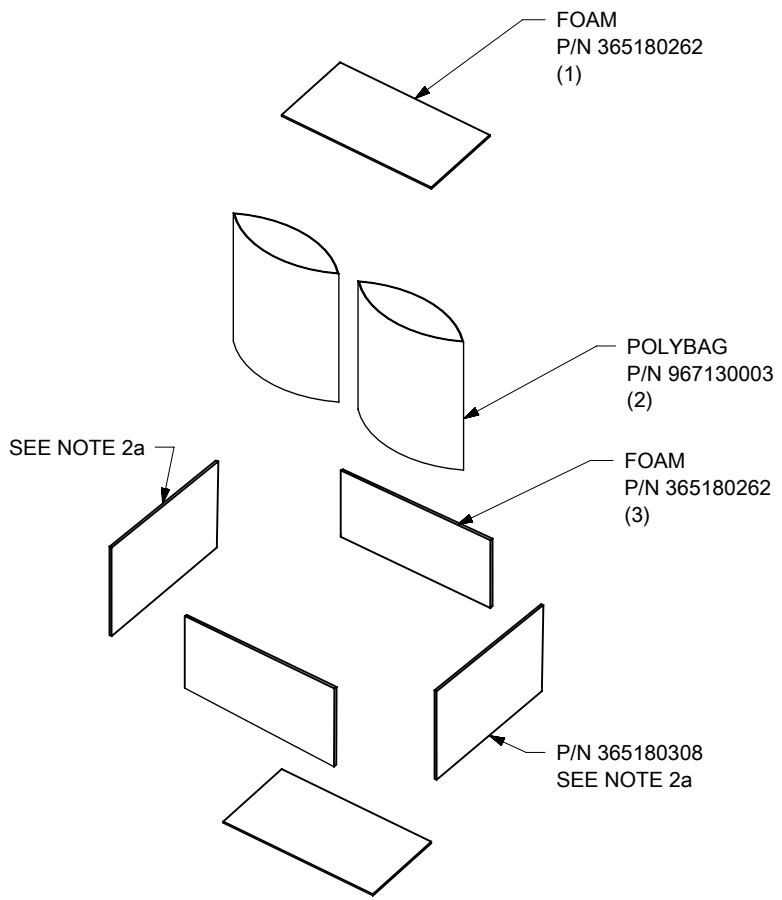

NOTES - PACKAGING PROCEDURE

1. FOLD AND TAPE BOTTOM FLAPS OF CARTON WITH 2" WIDE TAPE PER ES-40000-7013. TAPE SHOULD EXTEND UP SIDES OF CARTON AT LEAST 76 MM (3 INCHES). PLACE THE ADHESIVE TAPE IN CENTER & 2 CORNERS
2. PLACE THE FOAMS ALL SIX SIDES OF CARTON.
  - 2 a. CUT THE FOAM P/N 365180308 INTO TWO EQUAL HALVES AND PLACE TWO FACES
3. POLYBAGS TO BE FILLED WITH QUANTITY OF PARTS AS SPECIFIED PER CHART AND CLOSE POLYBAG BY HEAT SEALING.
4. CLOSE TOP FLAPS OF CARTON AND TAPE. TAPE SHOULD EXTEND DOWN SIDES OF CARTON AT LEAST 76 MM (3 INCHES).
5. ADD LABELS TO CARTONS AS REQUIRED PER ES-40000-7012.

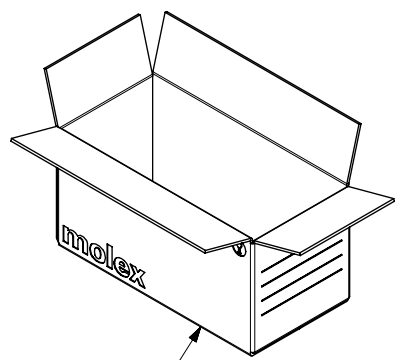

P/N 365180160

FUNCTIONAL SYMBOLS	THIS DRAWING CONTAINS INFORMATION THAT IS PROPRIETARY TO MOLEX ELECTRONIC TECHNOLOGIES, LLC AND SHOULD NOT BE USED WITHOUT WRITTEN PERMISSION									
	DIMENSION UNITS	SCALE	CURRENT REV DESC:							
$\frac{E}{A} = 0$	mm	NTS	EC NO: 778678 DRWN: GOWTHP 2021/12/30 CHK'D: JERRYW8 2024/02/29 APPR: XQZHANG 2024/03/01							
$\frac{E}{E} = 0$	GENERAL TOLERANCES (UNLESS SPECIFIED)									
$\frac{E}{P} = 0$	ANGULAR TOL ± °									
DIVISIONAL SYMBOLS	4 PLACES	±								
	3 PLACES	±	INITIAL REVISION:							
	2 PLACES	±	DRWN: SSHANMUGAN01 2019/03/12	DOCUMENT NUMBER	DOC TYPE	DOC PART	REVISION			
	1 PLACE	±	APPR: MRAMAKRISHNA 2019/12/19	2070170000-PK	PDD	000	C2			
	0 PLACES	±	DRAFT WHERE APPLICABLE MUST REMAIN WITHIN DIMENSIONS		THIRD ANGLE PROJECTION	DRAWING	SERIES	MATERIAL NUMBER	CUSTOMER	SHEET NUMBER
				A-SIZE	207017	SEE TABLE	GENERAL MARKET	2 OF 3		

207017 SERIES				
CKTS	PART NUMBER	PARTS PER BAG	BAGS PER CARTON	PARTS PER CARTON (DU)
4	207017-0004	1100	1	1100
6	207017-0006	950	1	950
16	207017-0016	500	1	500
18	207017-0018	450	1	450

214372 SERIES				
CKTS	PART NUMBER	PARTS PER BAG	BAGS PER CARTON	PARTS PER CARTON (DU)
16	214372-0001	500	1	500
	214372-0002			
	214372-0003			

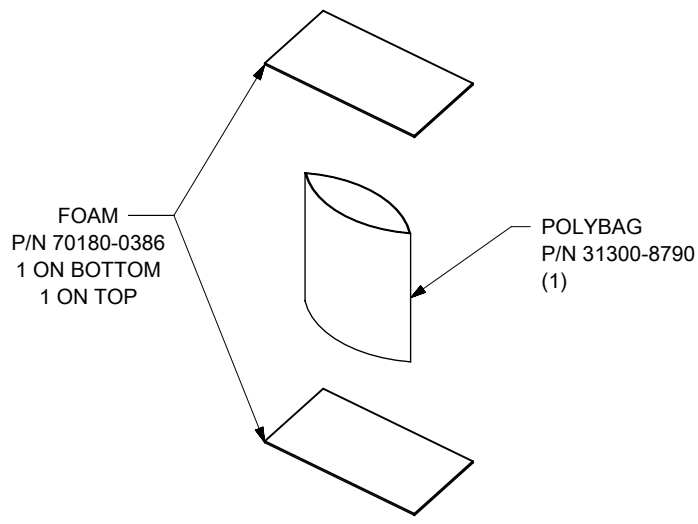

NOTES - PACKAGING PROCEDURE

1. FOLD AND TAPE BOTTOM FLAPS OF CARTON WITH 2" WIDE TAPE PER ES-40000-7013. TAPE SHOULD EXTEND UP SIDES OF CARTON AT LEAST 76 MM (3 INCHES). PLACE THE ADHESIVE TAPE IN CENTER & 2 CORNERS
2. POLYBAGS TO BE FILLED WITH QUANTITY OF PARTS AS SPECIFIED PER CHART, MOISTURIZED WITH 125mL DEIONIZED WATER PER AS-45499-001 AND POLYBAG CLOSED WITH TWIST LOCK 313017600, TWIST TIE, OR EQUIVALENT.
3. CLOSE TOP FLAPS OF CARTON AND TAPE. TAPE SHOULD EXTEND DOWN SIDES OF CARTON AT LEAST 76 MM (3 INCHES).
4. ADD LABELS TO CARTONS AS REQUIRED PER ES-40000-7012.

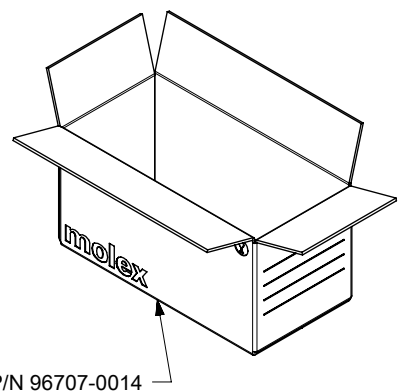

FUNCTIONAL SYMBOLS	THIS DRAWING CONTAINS INFORMATION THAT IS PROPRIETARY TO MOLEX ELECTRONIC TECHNOLOGIES, LLC AND SHOULD NOT BE USED WITHOUT WRITTEN PERMISSION													
	DIMENSION UNITS	SCALE	CURRENT REV DESC:											
$\frac{E}{A} = 0$	mm	NTS	EC NO: 778678 DRWN: GOWTHP 2021/12/30 CHK'D: JERRYW8 2024/02/29 APPR: XQZHANG 2024/03/01 INITIAL REVISION: DRWN: SSHANMUGAN01 2019/03/12 APPR: MRAMAKRISHNA 2019/12/19									PACKAGING SPECIFICATION FOR MINI-FIT SIGMA SEALED PLUG HOUSING		
$\frac{E}{E} = 0$	GENERAL TOLERANCES (UNLESS SPECIFIED)									PACKAGING DESIGN DRAWING				
$\frac{E}{P} = 0$	ANGULAR TOL ± °									DOCUMENT NUMBER		DOC TYPE	DOC PART	REVISION
DIVISIONAL SYMBOLS	4 PLACES	±								2070170000-PK		PDD	000	C2
	3 PLACES	±								MATERIAL NUMBER		CUSTOMER		SHEET NUMBER
	2 PLACES	±	207017		GENERAL MARKET		3 OF 3							
	1 PLACE	±	SERIES											
	0 PLACES	±												
DRAFT WHERE APPLICABLE MUST REMAIN WITHIN DIMENSIONS		THIRD ANGLE PROJECTION		DRAWING										
				A-SIZE										